

FEATURES

- *Rolling diaphragm provides excellent sensitivity and provides maximum constant effective area, which translates into improved linearity.*
- *Modular construction provides maximum part interchangeability between direct and reverse-acting models and between selected case sizes — field reversibility is easily accomplished.*
- *High spring rates improve control valve stability.*
- *Minimal guiding assures low hysteresis in reverse-acting models — zero hysteresis in direct-acting models.*
- *Stainless steel stems are standard for maximum performance in corrosive environments.*

D/R Series Spring-Diaphragm Pneumatic Linear Actuators

D/R Series actuators are linear spring diaphragm pneumatic actuators designed for reliable operation of control valves. The D/R is a rugged unit available in a combination of case sizes, strokes and springs to satisfy a wide range of applications.

The Type D, direct-acting actuator, strokes downward with an increase in air pressure. An opposing spring provides a fail-open response when attached to push-down-to-close globe control valves.

With the Type R, reverse-acting actuator, an increase in air pressure retracts the actuator stem, providing fail-close response when attached to push-down-to-close globe control valves.

For valves requiring longer travel and higher thrusts, the A46 and A47 are available. The A46 is a direct-acting actuator, while the A47 is a reverse-acting model.

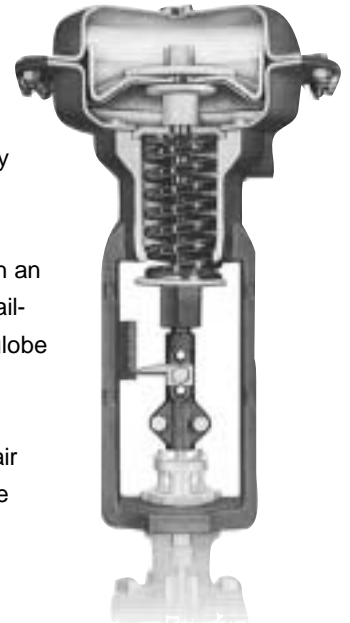

Specifications

Diaphragm Cases: Pressed steel

Stem: 303 S.S.

Diaphragm: Dacron reinforced nitrile

Spring Barrel: Cast Iron

Max. Case Pressure: D/R Series: 65 psi (4.5 bar)

A46/A47: 45 psi (3.1 bar)

Temperature Limits: -40° F to +180° F (-40° C to +82° C)

Top-Mounted Overrides/Limit Stops

When applications require, Type I override/limit stops (lift stops) are designed to (1) limit the degree of valve opening with either direct or reverse-acting actuators or (2) manually override direct-acting actuators. This type of stop is available with D/RA, D/RB and D/RC actuators. With direct-acting actuators, a built-in stop nut to limit stem lift is furnished as a standard feature.

Optionally available with RA, RB and RC reverse-acting actuators is a Type II override limit stop for use in overriding or limiting the degree of valve closing.

Bill of Materials and Parts

Parts For Models DA, DB, DC and DD — Direct-Acting

Part No.	Part Name	Material
1	Spring Barrel	Cast Iron
2	Diaphragm	Nitrile/Dacron
3	Piston	Carbon Steel
4	Upper Diaphragm Case	Carbon Steel
5	Lower Diaphragm Case	Carbon Steel
6	Spring	Carbon Steel
7	Spring Stem	303 Stainless Steel
8	Barrel Bridge	Stainless Steel
9	Packing Box Flange	Carbon Steel
10	Lower Case Gasket	Neoprene
11	Spring Adjuster	Carbon Steel
11A	Stop Nut	Carbon Steel
13	Packing Box	Brass
14	Packing Box O-Ring	Buna-N
15	Piston Back-up Plate	Carbon Steel
16	Diaphragm Button	Carbon Steel
17	Hex Head Cap Screw	Carbon Steel
18	Hex Nut	Carbon Steel
19	Hex Nut	Carbon Steel
20	Hex Head Cap Screw	Carbon Steel
21	Spring Adjuster Button	Carbon Steel
22	Diaphragm Disc	Carbon Steel
23	Travel Indicator Scale	Stainless Steel
24	Self Tap Screw	Carbon Steel
25	Diaphragm O-Ring	Buna-N
26	Split Coupling	Carbon Steel
27	Identification Tag	Stainless Steel
29	Travel Indicator	Stainless Steel
30	Spring Adjuster Screw	Carbon Steel
31	Spring Adjuster Thrust Bearing	Hardened Steel
32	Jam Nut	Carbon Steel
33	Spring Barrel Extension	Carbon Steel
34	Hex Head Cap Screw	Carbon Steel

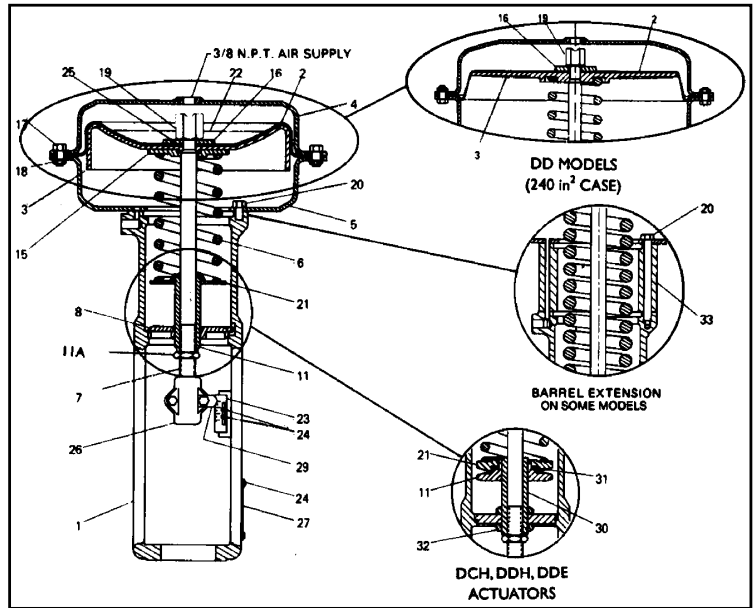

Parts For Models RA, RB, RC and RD — Reverse-Acting

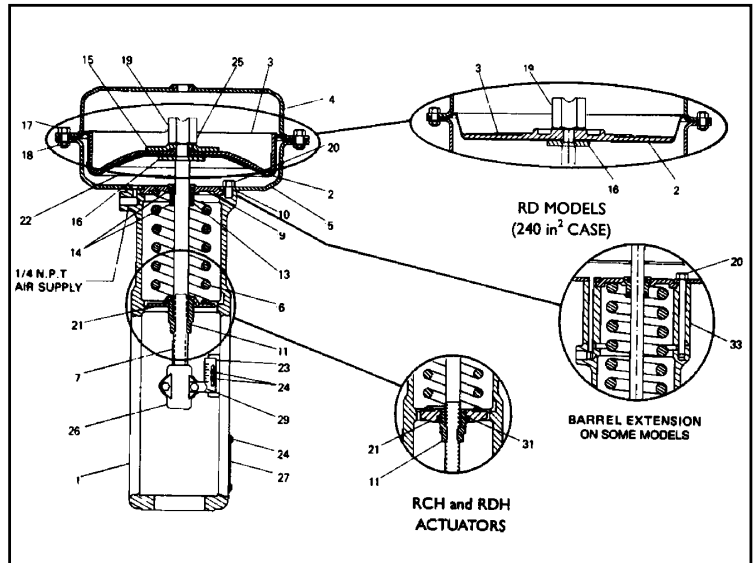

Type II Override/Limit Stop Assembly For Reverse-Acting Actuator

Type I Override/Limit Stop Assembly

Part No.	Name
1	Override/Limit Stop Diaphragm Case Assembly
2	Stem Assembly
3	Thread Sealing Washer*
4	Hex Nut

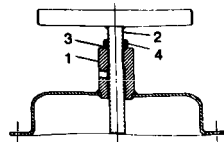

Part No.	Name
1	Limit Stop Diaphragm Case Assembly
2	Jacking Screw
3	Stem Nut
4	"T" Bar Hub
5	Set Screw
6	"T" Bar Handle
7	Thrust Washer
8	Hex Nut
9	Set Screw, Socket Jam

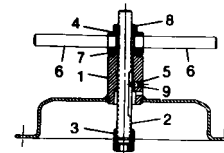

*Direct-acting actuators only

DIMENSIONS

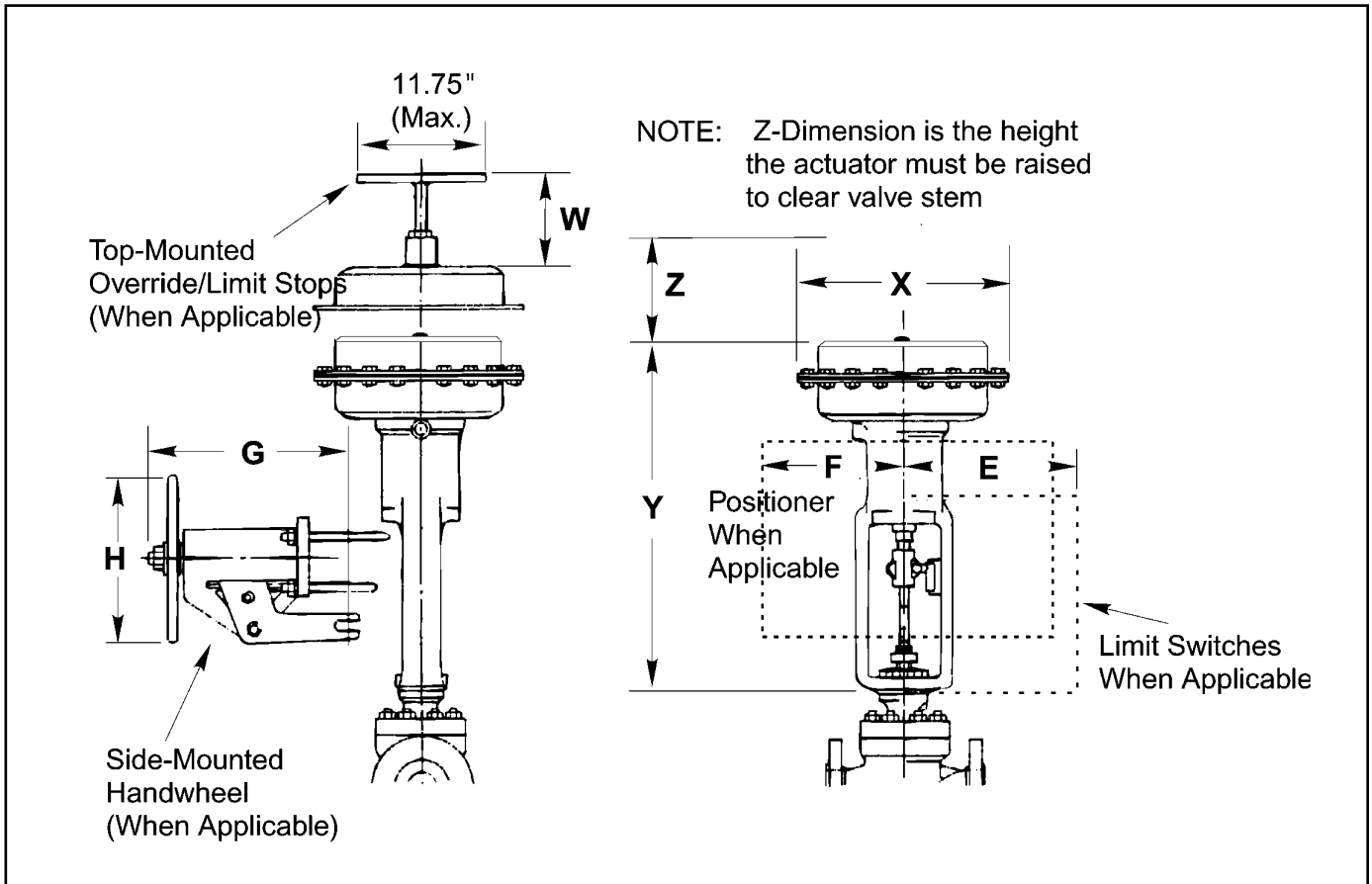

Actuator Model	Third & Forth Position Code	Actuator Dimensions — inches (mm)			Accessory Dimensions — inches (mm)				
		X	Y	Z (Max)	W Jackscrew	E (Max L.S.)	F (Max Posit.)	G (Max Hdwhl)	H (Norm Dia.)
DA/RA	DC, DD	12.00 (305)	18.75 (476)	6.50 (165)	5.88 (149)	8.00 (203)	12.00 (305)	12.00 (305)	10.00 (254)
DA/RA	C6, C8, DF, D5	12.00 (305)	21.63 (549)	6.50 (165)	5.88 (149)	9.00 (229)	12.00 (305)	12.00 (305)	10.00 (254)
DA/RA	C3, C4, D3, D4	12.00 (305)	23.10 (587)	6.50 (165)	5.88 (149)	9.00 (229)	12.00 (305)	12.00 (305)	10.00 (254)
DB/RB	C3, C4, D3, D4	13.81 (351)	23.35 (593)	6.50 (165)	5.75 (146)	8.00 (203)	12.00 (305)	12.00 (305)	10.00 (254)
DB/RB	CA, CB, DC, DD, E1, E2, EE	13.81 (351)	22.88 (581)	6.50 (165)	5.75 (146)	9.00 (229)	13.00 (330)	12.00 (305)	10.00 (254)
DC/RC	CA, CB	17.00 (432)	23.88 (607)	6.50 (165)	5.75 (146)	9.00 (229)	14.00 (356)	12.00 (305)	10.00 (254)
DC/RC	C3, C4, EA, EB	17.00 (432)	27.25 (692)	6.50 (165)	5.63 (143)	9.00 (229)	14.00 (356)	12.00 (305)	10.00 (254)
DC/RC	HF, H1, H2	17.00 (432)	32.50 (826)	8.50 (216)	5.75 (146)	9.00 (229)	14.00 (356)	12.00 (305)	10.00 (254)
DC/RC	D3, E3, E4	17.00 (432)	33.35 (847)	10.00 (254)	5.75 (146)	10.00 (254)	15.00 (381)	16.00 (406)	15.00 (381)
DD/RD	EA, EB, EC, ED	22.00 (559)	32.88 (835)	8.50 (216)	—	10.00 (254)	15.00 (381)	16.00 (406)	10.00 (254)
DD/RD	H1, H2	22.00 (559)	33.25 (845)	10.00 (254)	—	10.00 (254)	15.00 (381)	16.00 (406)	15.00 (381)
A46A	—	21.00 (534)	38.50 (978)	10.00 (254)	—	10.00 (254)	15.00 (381)	—	—
A46B*	—	21.00 (534)	47.00 (1194)	10.00 (254)	—	10.00 (254)	15.00 (381)	6.50 (165)	15.00 (381)
A47A	—	21.00 (534)	42.25 (1073)	10.00 (254)	—	10.00 (254)	15.00 (381)	—	—
A47B*	—	21.00 (534)	53.50 (1359)	10.00 (254)	—	10.00 (254)	15.00 (381)	6.50 (165)	15.00 (381)

* Integral handwheel is offset; minimal radial clearance is 9.25" (235mm).

How To Order

For actuator selection, refer to KOSO Hammel Dahl actuator selection guide. For options not shown or to enter an order, contact your local sales representative.

D/R Series

1	Model
D	Direct-acting—Stem extends with increased air pressure
R	Reverse-acting—Stem retracts with increasing air pressure

2	Case Size/ Mount/ Travel					
	Case Size	Mount	Travel			
0.750			1.000	1.125	1.500	2.250
56	2.125	AA	AD	AC		—
	2.812	—	—	AB	AE	—
84	2.125	BA	BD	BC	—	—
	2.812	—	—	BB	BE	—
140	2.125	—	CD	CC	—	—
	2.812	—	—	CB	CE	—
	3.562	—	—	—	—	CH
240	2.812	—	—	—	DE	—
	3.562	—	—	—	—	DH

3	Spring Span & Adjuster
	Refer to Actuator Selection Guide for proper combination.

4	Variations
A	Standard (no variations)
B	Type I Top-Mounted Override/Limit Stop*
C	Type II Top-Mounted Override/Limit Stop*
D	3/4-inch NPT Air Connections
Z	Special Actuator (See Factory)

*Refer to page 1 for limitations.

Subject to change without prior notice.

Side-Mounted Bolt-on Handwheel

The SM-1 or SM-2 side-mounted bolt on handwheel is available for D/RA, D/RB, D/RC and D/RD series actuators as shown in the following table.

To Mount On	Code	Model
DA or RA	All	SM-1
DB or RB	All	SM-1
DC or RC	All, Except H	SM-1
DC or RC	H	SM-2
DD or RD	All, Except H	SM-1
DD or RD	H	SM-2

A46/A47 Series

1	Model
A46	Direct acting - Stem extends with increased air pressure
A47	Reverse acting - Stem retracts with increased air pressure

2	Variations
A	Standard
B	Integral side mounted handwheel

3	Case Size
K	200 in ² nominal effective area

4	Mount
F	3.563 in. ² mount

5	Travel
8	3.5 in. travel

6	Spring Range
A	3 - 15 spring (standard for A46 direct acting actuator)
B	6 - 30 spring (standard for A47 reverse acting actuator)

7	Options
B	Standard construction

KOSO AMERICA, INC.
4 Manley Street
W. Bridgewater, MA 02379

Telephone: 508.584.1199
Fax: 508.584.2525
www.hammeldahl.com