

FEATURES

- Cage-retained "quick change" seat ring simplifies maintenance.
- Metal seats for a variety of services and ANSI Class IV shutoff.
- Soft seat inserts provide ANSI Class VI shutoff.
- Choice of 17-4PH or 316 stainless steel trim is standard.
- A wide range of trim sets is available; up to 7 reductions on some sizes.
- Bellows seal bonnet is available for difficult or hazardous chemical applications.
- Optional live-loaded PTFE and graphite packing.

Series G130 Globe And Angle Valves 1/2"-6" (DN15 - 150) ANSI Class 150-600

The G130 Series is a single-seated, top-guided control valve with "quick change" trim.

The seat ring is held in place by a retainer which is captured between the valve body and bonnet. No special tools are required for the removal or replacement of the seat ring.

The contoured plug of the G130 is available with 3 standard trim sizes (full, 60% and 40%) and up to 7 reductions in some sizes. The complete offering of body, bonnet and trim options make the G130 the first choice for the widest range of medias, temperatures and pressures.

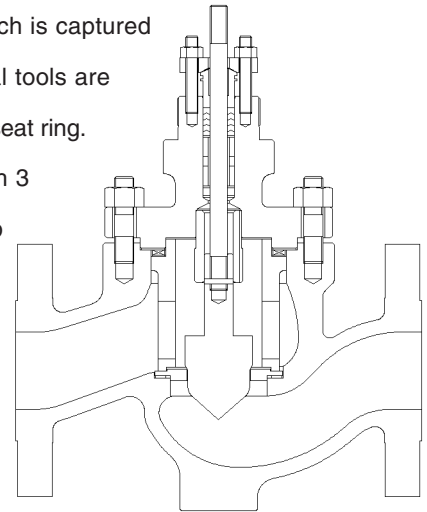

Specifications

Body Style: Globe or angle

Body Size: Globe - 1/2" through 6" (15-150mm)

Angle - 1/2" through 6" (15-50mm)

Body Rating: ANSI Class 150, 300, 600

Body Materials: Carbon steel, chrome-moly steel, stainless steel, other castable alloys including Monel®, Hastelloy®C, and Alloy 20 available on application

End Connections: NPT threaded or socket weld (1/2" through 2"); ANSI flanged (1/2" through 6"); ANSI butt weld (1" through 6"); others available on request.

Bonnets: Plain, extension, bellows seal, ultra-low temperature extension.

Trim Style: Unbalanced contoured plug, cage retained seat ring (refer to page 3)

Trim Characteristic: Linear and equal percentage

Flow Coefficient: C_v from 0.67 through 390 (refer to Tables on page 3)

Leakage Class: IV, V, VI

Actuators: Standard bonnet mount will accept spring-diaphragm, piston and other actuators. For actuator selection, refer to KOSO Hammel Dahl actuator selection guide.

Material Section

These charts should be used to select the pressure class and trim material combination. The curves sloping downward to the right are the pressure rating curves for each ANSI pressure class as listed in ANSI B16.34. In each case, the curve designates the maximum pressure and temperature for the class listed directly below the curve. The bold boundaries mark the recommended pressure and temperature limits for trim material combinations listed in the tables below. All recommendations are generalized and may be subject to adjustment based upon hydraulic considerations determined during the valve sizing process.

Figure 1.
Trim Chart for Stainless Steel Body
(ASTM A351, C8PM)

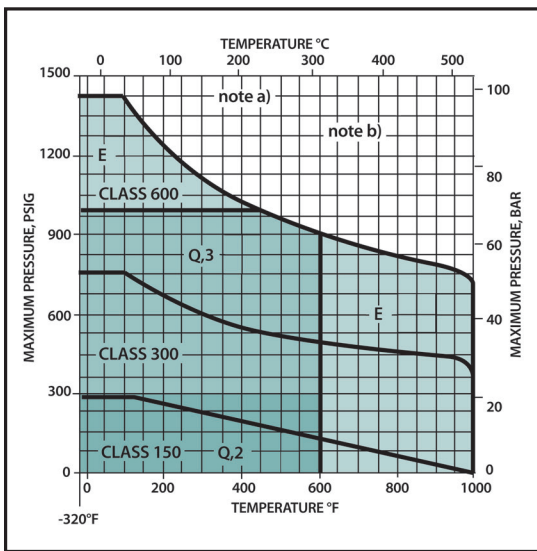

Figure 2.
Trim Chart for Carbon Steel Body
(ASTM A216, WCB)

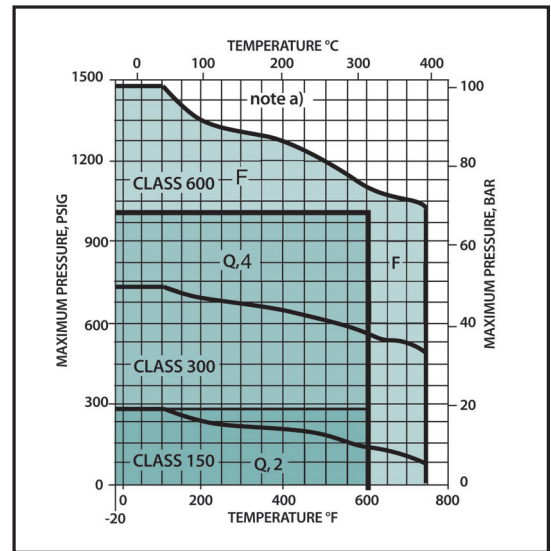

Figure 3.
Trim Chart for Chrome-Moly Body
(ASTM A217, C5)

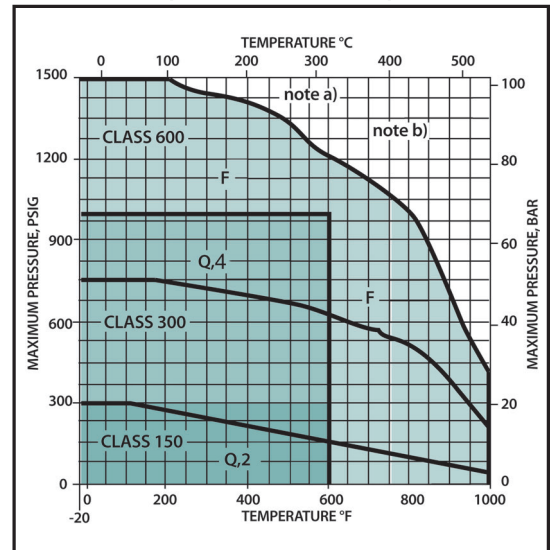

Table 1. G130 Standard Trim Materials

Trim Code	Plug	Seat Ring	Cage	Guide Bushing	Stem
2	316 SS	316 SS	316 SS	17-4PH	316 SS
Q	17-4PH	17-4PH	17-4PH	17-4PH	17-4PH
3	316 SS/HFS	316 SS/HFS	316 SS	17-4PH	316 SS
4	316 SS/HFS	316 SS/HFS	17-4PH	17-4PH	316 SS
E	316 SS/HFS+P	316 SS/HFS	316 SS	Alloy 12	316 SS
F	316 SS/HFS+P	316 SS/HFS	17-4PH	Alloy 12	316 SS
X	316 SS/PTFE	316 SS	316 SS	316 SS	316 SS

NOTES FOR TRIM TABLE

- a) Above +600°F (316°F) extension bonnet is required.
- b) For service temperature above +1000°F (+538°C) contact your local representative.
- c) Unless otherwise specified, the hard-facing is Alloy 6.
- d) CP= Chrome plated.
- e) For soft-seat trim selections see graph to right.
- f) KOSO Hammel Dahl reserves the right to substitute materials when appropriate based upon service or availability.
- g) Guiding surfaces are treated to prevent galling.

Figure 4.
PTFE Soft Seat Rating Chart

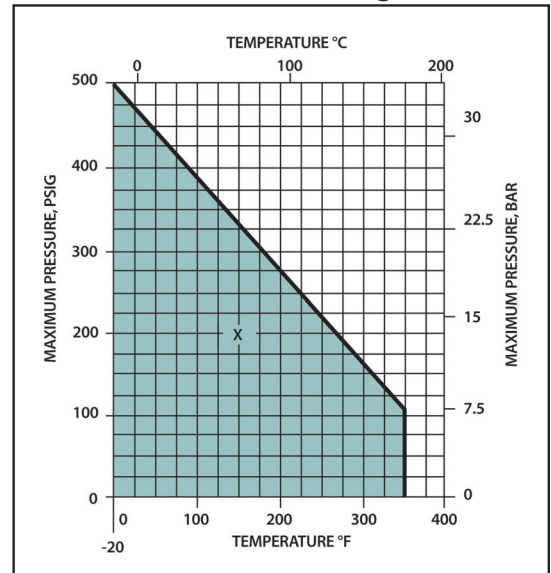

Bonnet Types

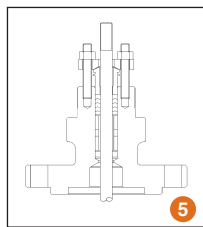

Figure 5. Plain Bonnet

A plain bonnet is used when the flow media remains between -50°F to 600°F (-46°C to +316°C); available with standard or live-loaded packing configurations.

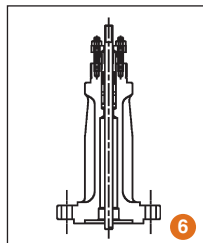

Figure 6. Extension Bonnets

An extension bonnet is required for low temperature applications between -200°F to -50°F (-129°C to -46°C) and high temperature applications from +600°F to +1000°F (+316°C to +538°C). Optional ultra-low temperature extension bonnet meeting ISA SP-79 height requirements is available for use at the same temperatures as above.

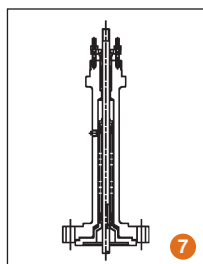

Figure 7. Bellows Seal Bonnets

A bellows seal bonnet is used when stem leakage cannot be tolerated because media is toxic, flammable, explosive or precious. Refer to the Bellows Seal Rating Chart for bellows temperature and pressure limits. For valves 3" - 6" bellows is internally pressurized as shown, 1/2" - 2" are externally pressurized.

Plug and Seat Designs

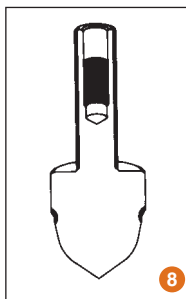

Figure 8. Standard Plug

The standard metal seated plug provides ANSI Class IV shutoff. ANSI Class V is available with lapping and proper actuator selection. Standard flow direction is from under the plug.

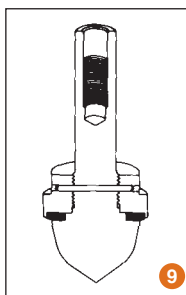

Figure 9. Soft Seat Design

The optional PTFE soft-seat insert is captured in the plug head and provides ANSI Class VI shutoff. For valves with Cv of 5.4 or smaller, the soft-seat insert is captured in the seat ring.

Figure 10. Bellows Seal Rating Chart

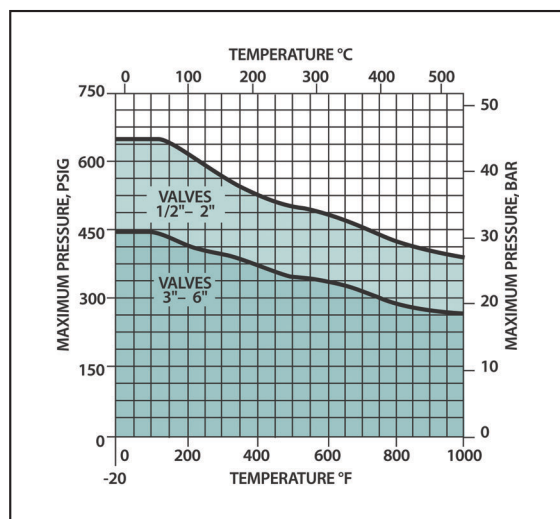

Table 2. Flow Coefficient (Cv) at Maximum Travel

Characteristic	Trim Size & Code		1/2	3/4	1	1-1/2	2	3	4	6
	Equal Percentage	Full Size	A	5.4	9.0	13.4	31	50	105	190
1 Reduction		B	3.6	5.4	9.0	13.9	32	49	105	192
2 Reduction		C	1.8	3.6	5.4	7.0	13.2	35	55	120
3 Reduction		D	1.4	1.8	3.6	- Not Available -				
4 Reduction		E	1.0	1.4	1.8					
5 Reduction		F	0.67	1.0	1.4					
6 Reduction		G	—	0.67	1.0					
7 Reduction		H	—	—	0.67					
Linear	Full Size	A	4.5	6.9	13.0	32	51	106	217	390
	1 Reduction	B	2.5	4.5	6.9	13.9	32	48	115	198
	2 Reduction	C	1.7	2.5	4.5	5.8	13.5	35	53	120
	3 Reduction	D	1.1	1.7	2.5	- Not Available -				
	4 Reduction	E	0.63	1.1	1.7					
	5 Reduction	F	0.48	0.63	1.1					
	6 Reduction	G	—	0.48	0.63					
	7 Reduction	H	—	—	0.48					

Weights and Dimensions

Table 3. G130 Globe Body Dimensions Data — inches (mm) ANSI Classes 150-600

Body Size	Travel	A						C	D				Approx. Weight lb/kg*
		Screwed or Socket Weld	Flanged			Butt Weld			Plain Bonnet	Extn. Bonnet	ULT Extn. Bonnet	Bellows Bonnet	
			Class 150-600	Class 150	Class 300	Class 600	Class 150-300						
1/2 (15)	1.00 (25)	8.12 (206)	7.25 (184)	7.50 (191)	8.00 (203)	—	—	2.38 (60)	5.38 (137)	9.59 (244)	13.50 (343)	14.10 (358)	25 (11)
3/4 (20)	1.00 (25)	8.25 (210)	7.25 (184)	7.62 (194)	8.12 (206)	—	—	2.38 (60)	5.38 (137)	9.59 (244)	13.50 (343)	14.10 (358)	25 (11)
1 (25)	1.00 (25)	8.25 (210)	7.25 (184)	7.75 (197)	8.25 (210)	8.25 (210)	8.25 (210)	2.38 (60)	5.38 (137)	9.59 (244)	13.50 (343)	14.10 (358)	25 (11)
1-1/2 (40)	1.12 (28)	9.88 (251)	8.75 (222)	9.25 (235)	9.88 (251)	9.88 (251)	9.88 (251)	3.19 (81)	5.88 (149)	11.10 (282)	15.50 (394)	16.10 (409)	65 (29)
2 (50)	1.12 (28)	11.25 (286)	10.00 (254)	10.50 (267)	11.25 (286)	11.25 (286)	11.25 (286)	3.62 (92)	5.92 (150)	11.45 (291)	17.52 (445)	18.12 (460)	70 (32)
3 (80)	1.50 (38)	—	11.75 (258)	12.50 (318)	13.25 (337)	13.25 (337)	13.25 (337)	4.38 (111)	7.27 (185)	11.81 (300)	19.27 (489)	19.27 (489)	145 (66)
4 (100)	1.50 (38)	—	13.88 (353)	14.50 (368)	15.50 (394)	14.50 (368)	15.50 (394)	5.31 (135)	8.08 (205)	11.96 (304)	23.89 (607)	23.89 (607)	230 (104)
6 (150)	2.25 (57)	—	17.75 (451)	18.62 (473)	20.00 (508)	17.75 (451)	20.00 (508)	6.62 (168)	9.87 (251)	14.68 (373)	26.06 (662)	26.06 (662)	470 (213)

*Weights are for ANSI Class 600 flanged valves with plain bonnet.

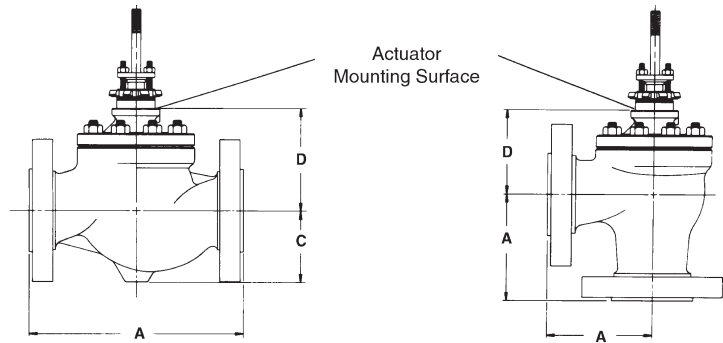

Table 4. G131 Angle Body Dimensional Data — inches (mm) ANSI Classes 150-600

Body Size	Travel	A						C	D				Approx. Weight lb/kg*
		Screwed or Socket Weld	Flanged			Butt Weld			Plain Bonnet	Extn. Bonnet	ULT Extn. Bonnet	Bellows Bonnet	
			Class 150-600	Class 150	Class 300	Class 600	Class 150-300						
1/2 (15)	1.00 (25)	4.06 (103)	—	—	—	—	—	4.56 (116)	8.78 (223)	12.69 (322)	13.29 (338)	25 (11)	
3/4 (20)	1.00 (25)	4.12 (105)	3.62 (92)	3.81 (97)	4.06 (103)	—	—	4.56 (116)	8.78 (223)	12.69 (322)	13.29 (338)	25 (11)	
1 (25)	1.00 (25)	4.12 (105)	3.62 (92)	3.88 (99)	4.12 (105)	3.62 (92)	3.62 (92)	4.56 (116)	8.78 (223)	12.69 (322)	13.29 (338)	25 (11)	
1-1/2 (40)	1.12 (28)	4.94 (125)	4.38 (111)	4.62 (117)	4.94 (125)	4.94 (125)	4.94 (125)	5.19 (132)	10.41 (264)	14.81 (376)	15.41 (391)	65 (29)	
2 (50)	1.12 (28)	5.62 (143)	5.00 (127)	5.25 (133)	5.62 (143)	5.62 (143)	5.62 (143)	5.00 (127)	10.52 (267)	16.59 (421)	17.19 (437)	70 (32)	
3 (80)	1.50 (38)	—	5.88 (149)	6.25 (159)	6.62 (168)	6.62 (168)	6.62 (168)	5.71 (145)	10.52 (267)	17.71 (450)	17.71 (450)	145 (66)	
4 (100)	1.50 (38)	—	6.94 (176)	7.25 (184)	7.75 (197)	7.25 (184)	7.75 (197)	6.90 (175)	10.78 (274)	22.71 (577)	22.71 (577)	230 (104)	
6 (150)	2.25 (57)	—	8.88 (226)	9.31 (236)	10.00 (254)	9.31 (236)	10.00 (254)	7.50 (191)	12.31 (313)	23.69 (602)	23.69 (602)	470 (213)	

*Weights are for ANSI Class 600 flanged valves with plain bonnet.

How To Order

To completely specify a control valve, make a selection from each category in the Valve Model Coding System below. The assembled codes create a complete valve model number. The Valve Model Coding System displays the standard product offering for this product line. An extensive number of options and variations exist, which are not listed. For options not shown or to enter an order, contact your local sales representative.

1	Series Models
G130	Globe Style Body
G131	Angle Style Body

2	Body Size
D	1/2" (15)
E	3/4" (20)
F	1" (25)
H	1-1/2" (40)
J	2" (50)
L	3" (80)
N	4" (100)
Q	6" (150)

3	Body Rating
G	ANSI Class 150
H	ANSI Class 300
F	ANSI Class 600

4	Body Material
C	Carbon Steel (ASTM A216, WCB)
E	Stainless Steel (ASTM A351, CF8M)
K	Chrome-Moly Steel (ASTM A217, C5)

5	End Connections
3	Raised Face Flange
4	NPT Threaded
6	Socket Weld
8	Butt Weld Sch. 40
9	Butt Weld Sch. 80

6	Bonnet Type
2	Plain
3	Ultra-low Temperature Extension
4	Extension
5	Bellows

7	Trim Characteristics
C	Linear
E	Equal Percent

8	Trim Size
A	Full Size
B	1 Reduction
C	2 Reduction

Refer to page 3 for additional trim reduction options.

9	Trim Materials				
Trim Code	Plug	Seat Ring	Seat Retainer	Guide Bushing	Stem
2	316 SS	316 SS	316 SS	17-4PH	316 SS
Q	17-4PH	17-4PH	17-4PH	17-4PH	17-4PH
3	316 SS/HFS	316 SS/HFS	316 SS	17-4PH	316 SS
4	316 SS/HFS	316 SS/HFS	17-4PH	17-4PH	316 SS
E	316 SS/HFS+P	316 SS/HFS	316 SS	Alloy 12	316 SS
F	316 SS/HFS+P	316 SS/HFS	17-4PH	Alloy 12	316 SS
X	316 SS/PTFE	316 SS	316 SS	316 SS	316 SS

10	Packing Options
G	PTFE V-Ring/Spacer
Y	Double PTFE V-Ring/Spacer
U	PTFE Impregnated PTFE Braid
W	Lubricated Aramid Braid
9	Laminated Graphite
B	Live-loaded PTFE V-Ring

11	Variations
—	None
A	Body Drain
B	Bonnet Lube Connection Only
D	Bonnet Lube Connection w/ISO Valve
G	Chlorine Clean
H	Oxygen Clean
J	125 RMS Flange Face Finish
K	17-4PH Stem
L	Tack Weld Guide Bushing Only
N	NACE Standard MR-01-75 Compliance

D/R Series Linear Spring Diaphragm Pneumatic Actuators

KOSO Hammel Dahl linear spring diaphragm pneumatic actuators are rugged units designed for reliable operation of linear control valves. The available combinations of case sizes, strokes, and springs precisely satisfy a wide range of application requirements.

FEATURES

- *Rolling diaphragm provides excellent sensitivity and provides maximum constant effective area which translates into improved linearity.*
- *Modular construction provides maximum part interchangeability between direct and reverse-acting models and between selected case sizes—field reversibility is easily accomplished.*
- *High spring rates improve control valve stability.*
- *Minimal guiding assures low hysteresis in reverse-acting models—zero hysteresis in direct-acting models.*
- *Stainless steel stems are standard for maximum performance in corrosive environments.*

Specifications

Diaphragm Cases: Pressed steel

Stem: 303 SS

Diaphragm: Dacron reinforced nitrile

Spring Barrel: Cast Iron

Max. Case Pressure: 65 psi (4.5 bar)

Temperature Limits: -40°F to +180°F (-40°C to +82°C)

Standard Spring Spans: 12 psi and 24 psi (.8 bar and 1.7 bar)
(other spans and spring preloads available on application)

REXA Electraulic™ Actuators

The REXA actuator is a programmable, self-contained, electro-hydraulic actuator designed specifically for modulating control. REXA actuators combine the speed, power and repeatability of non-compressible hydraulics with the flexibility of a dedicated microprocessor. Available in a wide range of sizes and product options, there is a REXA actuator to meet even the most demanding control applications.

Positioners

Pneumatic, electro-pneumatic and digital positioners improve repeatability and accuracy while providing increased force to reduce actuator sizes. Pneumatic positioners accept a 3-15 psi input, while electro-pneumatic positioners typically accept a 4-20 mA signal. Most digital positioners provide extensive monitoring or diagnostics, as well as improved response speed. Several industry-recognized brands are offered, including KOSO's own. Others are available upon request.

Other Accessories

Additional accessories available for mounting with linear control valves include, but are not limited to transducers, limit switches, lock-up valves, solenoid valves and amplifying relays. Please consult the factory for complete details.

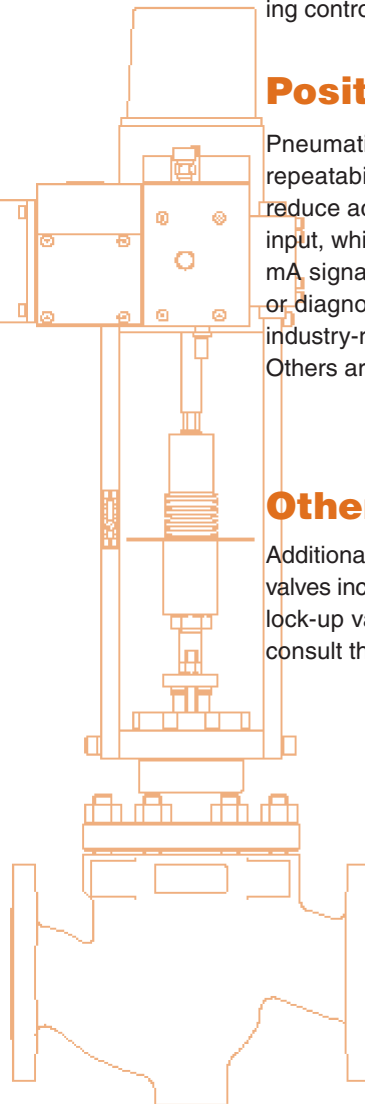

KOSO AMERICA, INC.

4 Manley Street

W. Bridgewater, MA 02379

Telephone: 508.584.1199

Fax: 508.584.2525

www.hammeldahl.com

CONTROL VALVES

KOSO HAMMEL DAHL